



There are potential fire and life safety issues associated with vacant properties which pose risks to members of the community and city staff.

In the City of Richmond, it is the responsibility of the property owner to secure and maintain the security of their vacant premises, until demolition is achieved.

The property owner(s) or their agent(s) who have vacant properties are responsible for:

- securing and maintaining the condition of their property (structures and land)
- reducing the risk of fire and other life safety matters
- inspecting regularly and taking corrective measures

The hazards and risks associated with vacant premises are mitigated through the enforcement of maintaining and securing vacant premises under the powers of the Fire Protection and Life Safety Bylaw No. 8306 as defined below:

9.7 Vacant Premises

9.7.1 For the purpose of this Section, vacant premises includes a lot, building or other structure in respect of which a water or electricity service has been intentionally discontinued, other than for temporary maintenance, repair or upgrading, so that the condition of the premises is not suitable for human habitation or other occupancy that is normally permitted.

9.7.2 The owner of vacant premises must promptly act to ensure that, at all times:

- (a) the premises are free from litter and debris or accumulations of combustible or flammable materials except where storage of combustible or flammable materials is in strict accordance with the Fire Code and this Bylaw; and
- (b) all openings in the premises are securely closed and fastened in a manner acceptable to the Fire Chief so as to prevent fires and the entry of unauthorized persons.

9.7.3 Where an owner fails to securely close a vacant building as required by Subsection 9.7.2 (b), the Fire Chief may, by notice in writing, order the owner to secure the building or other part of the vacant premises against unauthorized entry in a manner set out in the notice.

9.7.4 If an owner of vacant premises fails to bring the premises into compliance with this Bylaw within twenty-four (24) hours of receiving a notice under Subsection 9.7.3, or if the Fire Chief or member is unable to contact the owner within twenty-four (24) hours of finding vacant premises in an unsecured state, the Fire Chief may cause the premises to be secured by City employees or agents, who may board up or otherwise secure doors, windows and other points of entry into the premises in order to prevent fires and unauthorized entry, at the cost and expense of the owner.

Materials List and Specifications

Security Measures:

- All openings in the basement, first floor doors and windows, and any point of entry accessible from a porch, fire escape or other potential climbing point shall be barricaded with plywood, 2 x 4 braces, carriage bolt sets, and nails. Particle board, wafer board, Masonite, or other similar material shall not be used for purposes of boarding-up a building.
- Openings that are 10' from ground level which are not accessible from a porch, fire escape, roof or other climbing point do not need to be secured unless any of the following conditions exists:
 - (a) openings are unlockable, or
 - (b) openings are visibly broken or damaged.
 Where (a) or (b) are met, the openings may be secured from within the structure with a single piece of plywood.
- *Where the structural or environmental conditions exists and it is not safe to secure the opening from the inside, the opening shall be secured from the exterior with the plywood fitted flush and tight to the perimeter, rests snugly against the exterior frame butting up to the siding on wood frame building, or in the case of brick buildings, up to the brick molding edge.
- All secured exterior openings (windows and doors) will be painted flat black in color
- The structure shall be posted with a NO TRESPASSING sign at the completion of the board-up. The posting will be displayed as Fire Protection and Life Safety Bylaw 8306 7.10 Street Addresses



Richmond Fire-Rescue
604-278-5131
firerescue.richmond.ca



RCMP
604-278-1212
www.richmond.ca



Richmond
Community Bylaws
604-276-4345
www.richmond.ca

Table 7.10

Distance measured from public street curb to building	Size Height (mm)	Stroke Width (mm)
Up to 15m	75	18.0
>15m to 20m	100	25.0
>20M to 25m	150	32.0
>25m to 35m	200	38.0
>35m to 40m	250	42.0
>40m	300	50.0

Materials

- 1/2" CDX Plywood, exterior grade (4 ply)
- 2 x 4 construction grade lumber
- 3/8-16 x 12" carriage bolts (rounded head on weather side)
- 3/8-16 construction grade nuts
- 1/2" (USS Standard) Flat washers with an inside diameter large enough to bypass the wrench neck inside the carriage bolt head so no lift edge is available beneath an installed carriage bolt head.
- 3/8" (USS Standard) diameter flat washers for installation beneath the nut inside the building

As required:

1 5/8" (6D) galvanized or stainless steel ring-shank nails or comparable deck nails.

2.5" Torx Bit screws

Barrier Assembly

- Applying barriers is accomplished with an inside and outside carpenter with appropriate tools and supplies. The inside carpenter will need a light. Exit is made over a ladder when the last window is boarded.
- Plywood shall be cut to fit over the window and door openings, flush with outside of the molding/trimmer stud. Application of barriers shall be completed so that all lift or pry points are avoided.
- The 2 x 4 braces shall be cut to fit the horizontal dimension of the plywood. (x2) exterior and (x2) interior 2 x 4 braces shall be provided for each window and (x3) sets for each door.
- Window Assembly – Braces are located horizontally approximately 1/3 of the distance from the top and the bottom of the window. Bolt holes are located 1/3 of the length of the brace from the outside edge of the window jams. Prior to installation, the assembly should be pre-assembled and 3/8" holes drilled through all of the components.

- Door Assembly – Door braces will be placed horizontally; one in the center of the doorway and one 1/2 the distance from the center to the top and one 1/2 distance from the center to the bottom of the doorway. Bolt holes are located 1/3 of the length of the brace from the outside edge of the door frame. Prior to installation, the assembly should be pre-assembled and 3/8" holes drilled through all of the components.
- Plywood used to cover exterior openings shall be nailed every 12" c/c along the perimeter to the window or door frame.
- The 2 x 4 braces on the interior and exterior of the assemblies shall be secured using 3/8-16 x 12" carriage bolt assemblies. Bolts shall be inserted through the pre-drilled holes from the exterior with a 1/2" washer place against the exterior brace, a 3/8" washer is placed against the interior brace. The bolt is tightened from the inside so that it slightly compresses the interior brace.
- The exterior surfaces of barriers shall be painted or stained flat black to minimize the appearance.

*Should the through-bolt compression method be impossible due to the size or condition of the opening, the opening shall be covered with plywood and secured with a minimum of 2.5" Torx Bit screws installed on 4" c/c around the perimeter of the opening.

For buildings that require access by authorized personnel, a single door that is visible from the street may be secured using a solid core wood or steel door. There shall be no windows or other openings in this door. The door shall be securely locked using a padlock and hasp assembly that is bolted through the door. The lock loop portion of the hasp is attached to the door frame using a minimum of 2.5" Torx Bit screws.

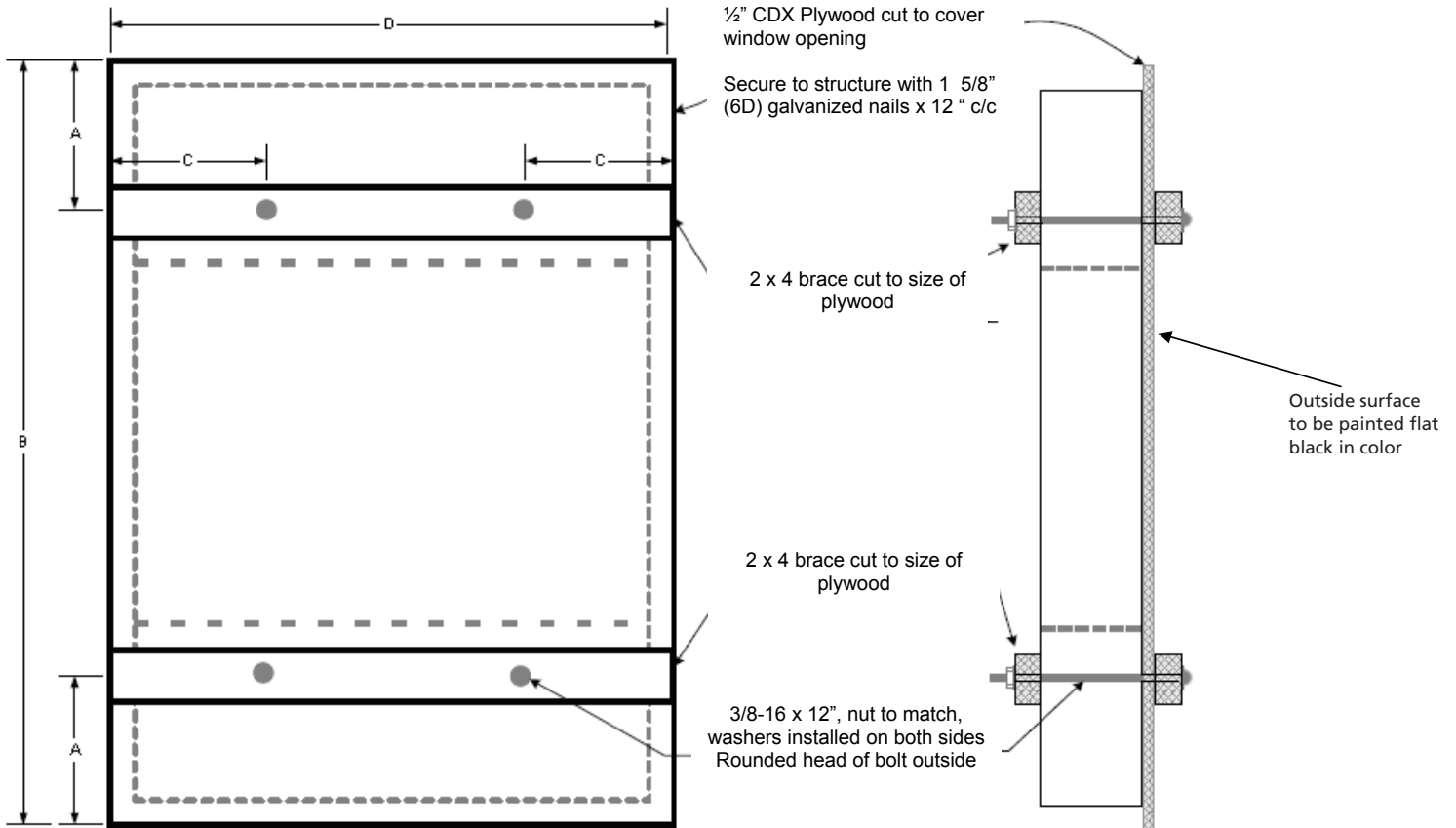

WINDOW – Outside View

NOTES:

1. For double hung windows, slide sash to center of unit and pass bolts through the openings at top and bottom
2. Storm windows should be removed and stored inside premises.
3. Outside trim may have to be removed to accommodate a flush tight fit.
4. Tighten nuts from inside enough to slightly compress 2 x 4 brace.
5. Brace locations: $A = 1/3 B$ (See dimension locations on drawing)
6. Location of bolt holes: $C = 1/3D$ (See dimension locations on drawing)

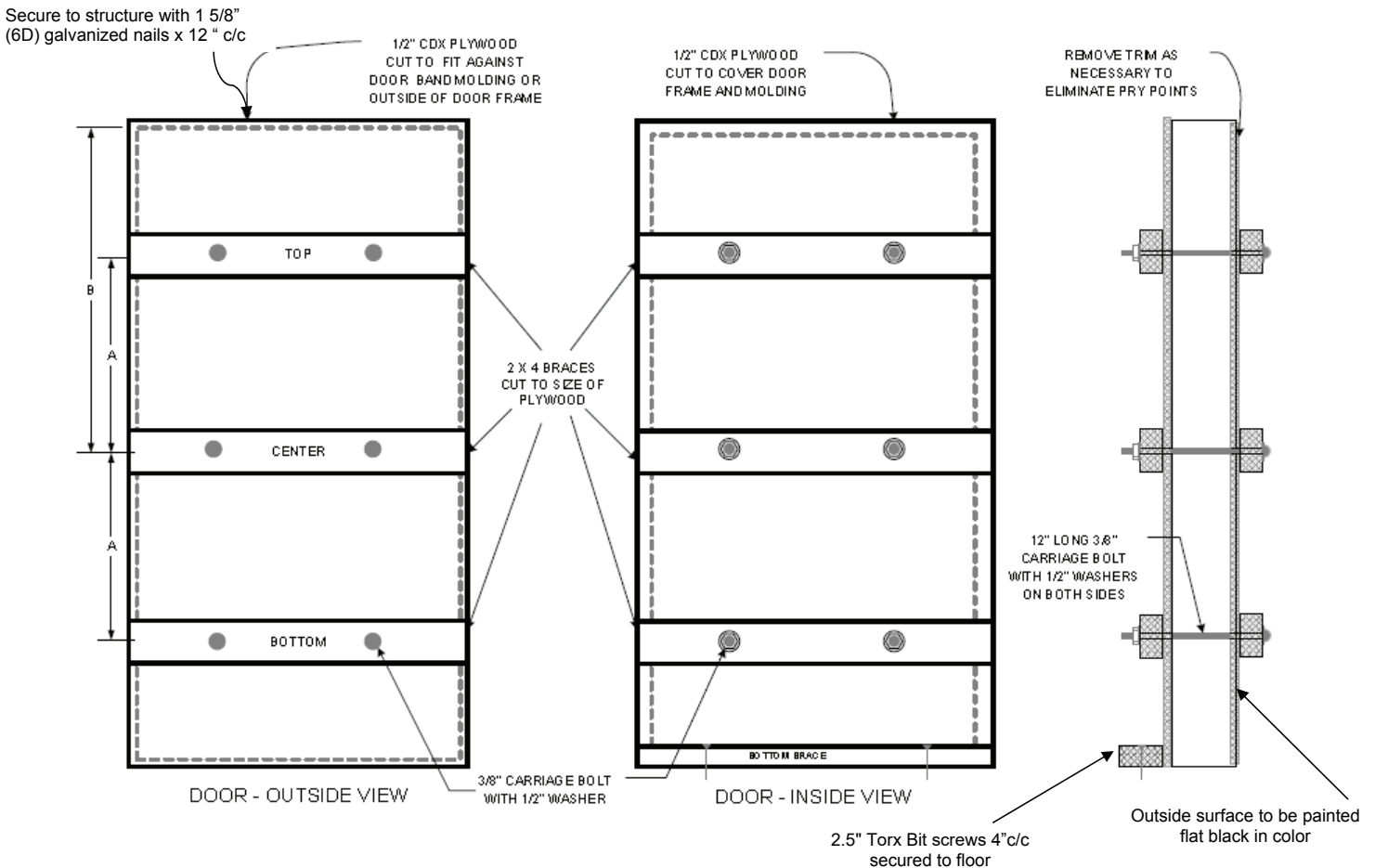

NOTES:

- Door is removed and stored inside of building.
- Use 3/8-16 x 12" Carriage bolts – rounded head on outside of building
- Tighten nuts from inside enough to slightly compress 2 x 4 brace.
- If plywood cannot be butted against band molding, cut to cover outside edge of door frame.
- Bolt holes are located as they are for windows detail (see window detail)
- Center brace located in center of doorway opening. Top and bottom braces are positioned where $A = 1/2B$ (see dimension locations on drawing)
- Adhesive/Resin to be applied over the screw heads.

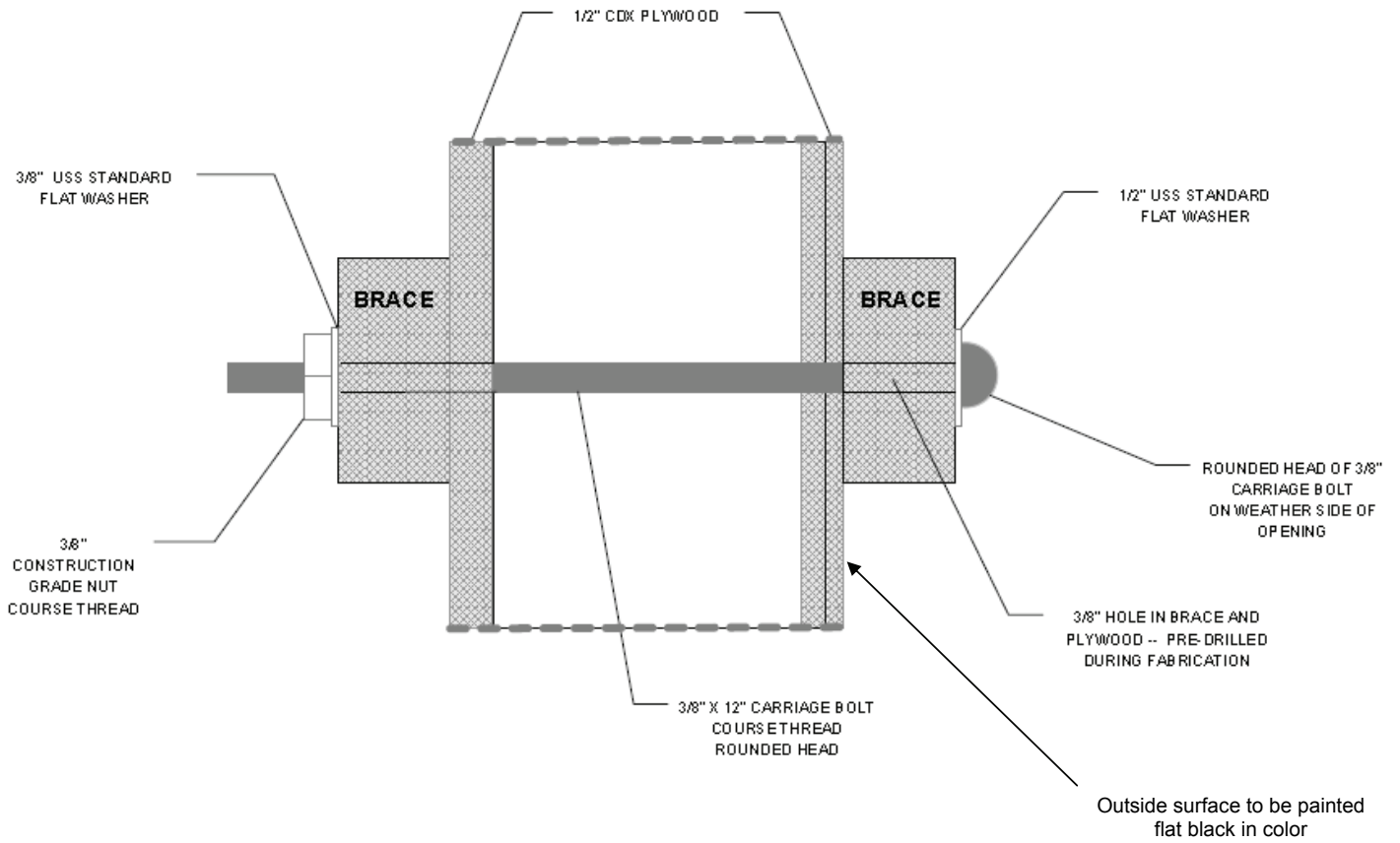

NOTES:

- Use 3/8-16 X 12" carriage bolts – rounded head on outside of building
- Tighten nuts from inside enough to slightly compress washer into 2 x 4 brace.
- Use 1/2" Washer on weather side to accommodate the wrench neck of bolt and eliminate pry points.

MATERIALS LIST

WINDOW ASSEMBLY

Materials required per window

- (x1) 1/2" CDX Plywood – cut to dimensions of window frame (weather side) Number of windows to be secured (NW):
- (x4) 2 x 4 braces – cut to width of plywood - Number of window braces required: (NW X 4)
- (x4) Carriage Bolt assemblies - Carriage bolt assemblies required (BW): (NW X 4)

As required:

1 5/8" (6D) galvanized or stainless steel ring-shank nails or comparable deck nails.

2.5" Torx Bit screws



DOOR ASSEMBLIES

Materials required per door

- (x1) 1/2" CDX Plywood sheet – cut to dimensions of door frame (weather side) – number of doors to be secured (ND):
- 1/2" CDX Plywood sheet – cut to outside dimensions of door frame (inside)
- (x1) 2 x 4 braces – (x3) cut to width of outside plywood, (x3) cut to width of inside plywood - number of door required: (No. x 6)
- 2 x 4 bottom brace – cut to width of door trim - number of bottom braces required: (No.)
- (x6) Carriage bolt assemblies - carriage bolt assemblies required (BD): (No x 6)

As required:

1 5/8" (6D) galvanized or stainless steel ring-shank nails or comparable deck nails.

2.5" Torx Bit screws

CARRIAGE BOLT ASSEMBLY

- (x1) 3/8-16 x 12" Carriage bolt
 - (x1) 1/2" USS Standard flat washer (weather side)
 - (x1) 3/8" USS Standard flat washer (inside)
 - (x1) 3/8-16 Construction grade nut
- Total carriage bolt assemblies (BW + BD)

References:

IAAI/USFA Abandoned Building Project – Board-up Procedures

Richmond Fire-Rescue